

# ICP2432B - for PCIbus

# PROTOGATE

**P**rotogate's ICP2432B is a programmable intelligent communications processor specifically designed for serial data communications. The ICP2432B links legacy and specialty serial data with today's state-of-the-art computers. The CPU on the ICP2432B handles all the high-speed data transfer and interrupt-intensive processing associated with serial communications. This makes the ICP2432B ideal for real-time, mission-critical applications. The programmability of the ICP2432B ensures that it can adapt as connectivity requirements change with the addition of serial protocols, clients, or devices. The ICP2432B can be installed in Protogate's Freeway line of network servers or can be embedded in one of several supported PCIbus computer systems.



## WIDE VARIETY OF PROTOCOLS

Over 50 different legacy and specialty protocols are available for use with the ICP2432B. With extensive experience in WAN protocol development, Protogate maintains the industry's most extensive library of legacy and specialty protocols, and is a leading supplier of network-level and link layer protocols such as X.25, HDLC, BSC, Async, financial market protocols, and a wide variety of tactical, military, and radar protocols.

## DESIGNED FOR PERFORMANCE

The ICP2432B enhances system performance by off-loading CPU-intensive communications protocol processing and associated interrupts from the host processor. The ICP2432B can be configured with 2, 4, or 8 serial ports in a single PCI slot that can be programmed to support different line speeds. 32MB of on-board SDRAM provides ample storage for complex protocol software and data. In addition, on-board data buffering is useful for applications involving data segmentation, bursts of data, or host processing delays. The ICP2432B contains a PCIbus mastering interface with dual FIFO registers and a mailbox interface.

## PROGRAMMABILITY

The ICP2432B is programmable for bit-synchronous, byte-synchronous, and asynchronous protocols to provide real-time support for data communications. All protocol software is downloaded to on-board SDRAM, ensuring easy system support and field upgrades. The ICP2432B is fully software configurable without the need for on-board switches or jumpers.

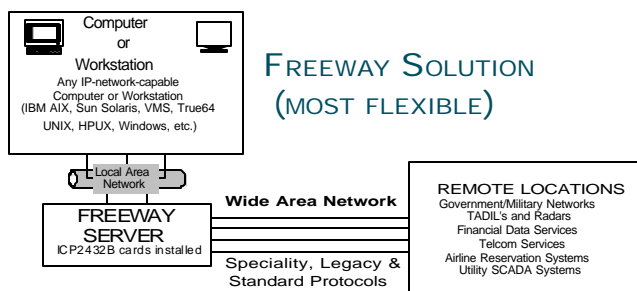

## FEATURES

- Installs into industry standard 3.3 or 5.0 volt PCIbus slots
- Off-loads CPU-intensive communication protocol tasks
- Extensive library of pre-programmed WAN protocols plus custom protocol development available from Protogate
- Supports up to 8 serial ports in a single PCI slot
- Uses Motorola Coldfire CPU with 32MB SDRAM and full-duplex DMA support for serial ports
- Optional ProtocolToolkit allows for customer-developed WAN protocols

## BENEFITS

- Links legacy and specialty networks to PCI-based computers
- Improves host processor performance
- Provides flexibility for a wide range of WAN communication applications
- Allows more serial ports per host system
- Achieves serial data rates up to T1 speeds for use in real-time, mission-critical applications
- Ideal for developing classified or

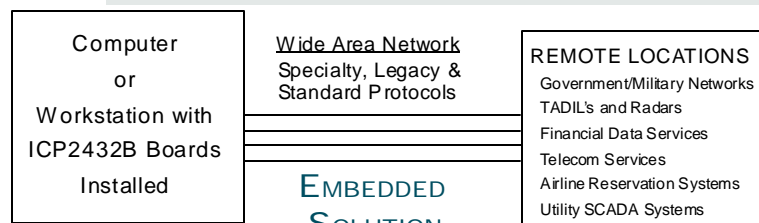
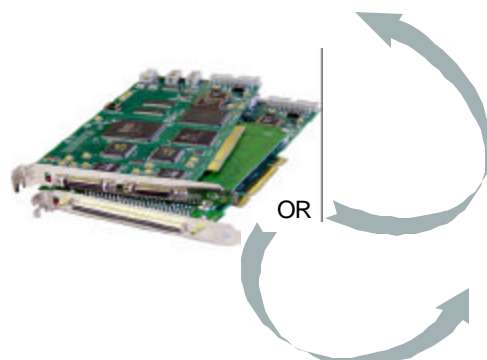

# PROTOGATE

## Largest Selection of Protocols

### General, Commercial

Asynchronous  
ADCCP  
Bitstream  
BSC 2780/3780  
BSC 3270  
DDCMP  
HDLC LAPB  
SDLC  
X.25  
TCP/IP  
RRP117

### Financial Services

FMP 40 Protocols  
IP Multicast  
CHIPS II  
SWIFT II

### Government, Military, and Radar<sup>1</sup>

ADCCP ABM/NRM  
ATDL/UDL  
AUTODIN  
BISYNC Radar  
CD2  
CF  
GDL  
ICAO  
IDL  
Lateral Tell  
LINK-1  
LINK-11B  
LINK-14  
LRR  
MCC  
MBDL  
MTDL  
Nine-Bit-Radars  
NOAH  
SR162/172  
STD 1200B  
STD1300  
X.25

<sup>1</sup> Call for custom quote.

Protogate, Inc.

Trade names referenced are the trademark or registered trademark of the respective manufacturer. The information contained in this document is subject to change without notice.

## HIGH THROUGHPUT CONNECTIONS

For high throughput and efficient protocol processing, the ICP2432B features a Motorola MCF5407 "Coldfire" embedded processor and 2, 4, or 8 Zilog Z16C32 communications processors that enable multiple high-throughput connections. Each serial port has two DMA channels that provide full-duplex support between on-board memory and the serial ports.

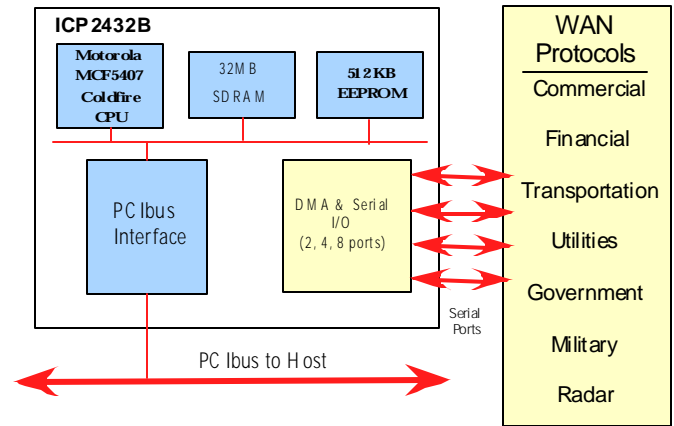

ICP2432B ports are independently configurable for different characteristics such as line speed, modem control, and clock source. The electrical interfaces for the 2 and 4 port versions can be configured to support a wide variety of electrical interfaces including EIA-232, EIA-449, EIA-530, MIL-STD-188-114A, and V.35. The 8 port version supports EIA-232 only.

## USING THE ICP2432B

The ICP2432B is a 33 MHz/32 bit "universal" board which can plug into both 5V and 3.3V PCIbus connectors. Note: 64 bit transactions are negotiated in real time and are transparent to 32 bit devices. Protogate provides installation software, device drivers, and protocol software.

## TOOLKIT SUPPORT

Protogate offers a Protocol Toolkit to support development and integration of private or custom protocols. This Toolkit provides everything needed to port a private or custom protocol to the ICP2432B.

## Technical Specifications

Processor	Motorola MCF5407 "Coldfire" CPU
Memory	32MB SDRAM
Serial Ports	2, 4, or 8 full duplex, DMA supported ports; Z16C32 serial communications controllers; data rate of each port software selectable; transmit clock source software selectable for synchronous communication; mandatory and optional modem control signals provided
Electrical Interfaces	EIA-232 (2, 4, or 8 ports; other interfaces in 2 or 4 ports only) EIA-449 (422) EIA-530 MIL-STD-188-114A V.11 (ISO-4903) V.21 bis V.35/Bell 306
Mechanical Interfaces	2-port: 2 micro-D 26 pin sockets. Micro-D to DB25-p or DB37-p cables available. 4-port: 1 high density 100 pin socket. High density 100 pin to 4 DB25-p or DB37-p cable available. 8-port: 1 high density 100 pin socket. High density 100 pin to 8 DB25-p cable available.
Power Requirements	2-port: +5Vdc, 1.5A typical 4-port: +5Vdc, 1.75A typical 8-port: +5Vdc, 2.0A typical
Physical	PCI card form factor, 9 inches in length
Environmental	Temperature: 0° to 50° C, operating, -40° to 65° C, non-operating Humidity: 10% to 90% R.H., non-condensing Altitude: 0 to 10,000 feet



CAB-51-DB-25 Cable for ICP2432B-4

**PROTOGATE**

Copyright 2002, Protogate, Inc. All Rights Reserved

12225 World Trade Drive • Suite R • San Diego, CA 92128

Tel: 858.451.0865 • Web: [www.protogate.com](http://www.protogate.com) • Email: [sales@protogate.com](mailto:sales@protogate.com)